

GURTEC

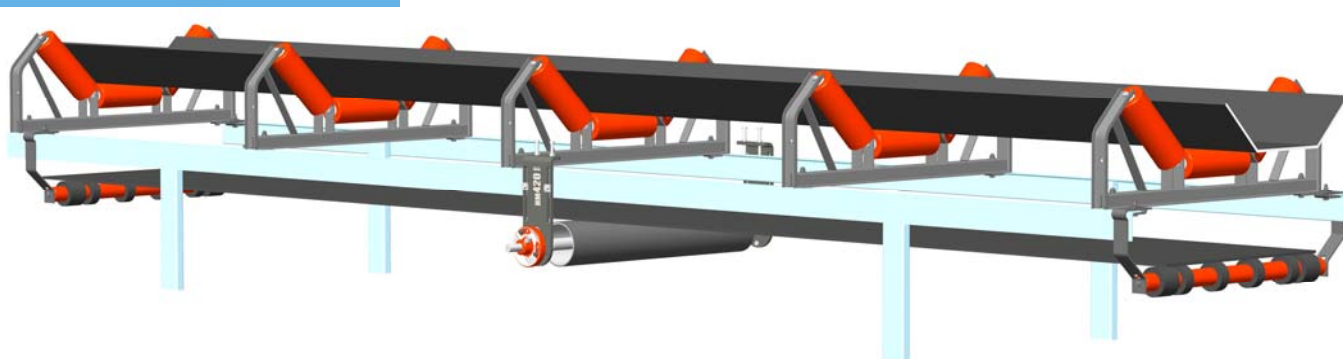

Trogstellen en steunen voor transportbandrollen

ALGEMENE CATALOGUS



s.g.t.
nv
sa

Chaussée de Wavre 362
B-1390 Grez-Doiceau
België

Telefoon : +32-10-84.29.25
Fax : +32-10-84.21.74
Mail : info@sgt-promati.com
Web : www.sgt-promati.com

s.g.t.
nv
sa



INDEX :

	Page :
2-delige en 3-delige trogstellen:	
• Standaard 3-delige trogstellen, voorradig	2
• 3-delige trogstellen volgens NFE53300	3
• 2-delige trogstellen volgens NFE53300	4
• Standaard 2-delige trogstellen op U-60 volgens DIN	5
• Standaard 2-delige trogstellen op U-100 volgens DIN	6
• Standaard 3-delige trogstellen op U-60 volgens DIN	7
• Standaard 3-delige trogstellen op U-100 volgens DIN	8
Steunen voor vlakke rollen	
• Steun voor bovenrol, zware uitvoering	9
• Steun voor onderrol, zware uitvoering	10
• Steun voor onderrol	11
Voorbeelden van speciale uitvoeringen	12-13
Referenties	14
Contacteer ons	15



Norm : DIN
 Voor rollen : GUP Ø 63,5—89—108 mm, as 20 mm, SW15x10 mm
 Bescherming : Epoxy-coating, ovengebakken (op aanvraag warm verzinkt)
 Toespoor : Naar keuze (2 sleuven)

Referentie	Band- breedte [mm]	Trog- hoek α [°]	Dwarsprofiel		Entre-axe perçage [mm]	Lengte rol RL [mm]	Gewicht [kg]
			type []	Lengte L [mm]			
2000000	500	25	U-100	800	740	200/206/226	8,2
2000002	500	30	U-60	800	740	200/206/226	6,3
2000004	500	30	U-100	800	740	200/206/226	8,6
2000006	650	20	U-60	950	890	250/256/276	6,5
2000008	650	20	U-100	950	890	250/256/276	9,1
2000010	650	25	U-100	950	890	250/256/276	9,4
2000012	650	30	U-60	950	890	250/256/276	7,9
2000014	650	30	U-100	950	890	250/256/276	10,6
2000016	800	20	U-100	1150	1090	315/321/341	10,9
2000018	800	25	U-100	1150	1090	315/321/341	12,1
2000022	800	30	U-60	1150	1090	315/321/341	9,2
2000024	800	30	U-100	1150	1090	315/321/341	12,5
2000026	1000	30	U-100	1350	1290	380/386/406	14,2

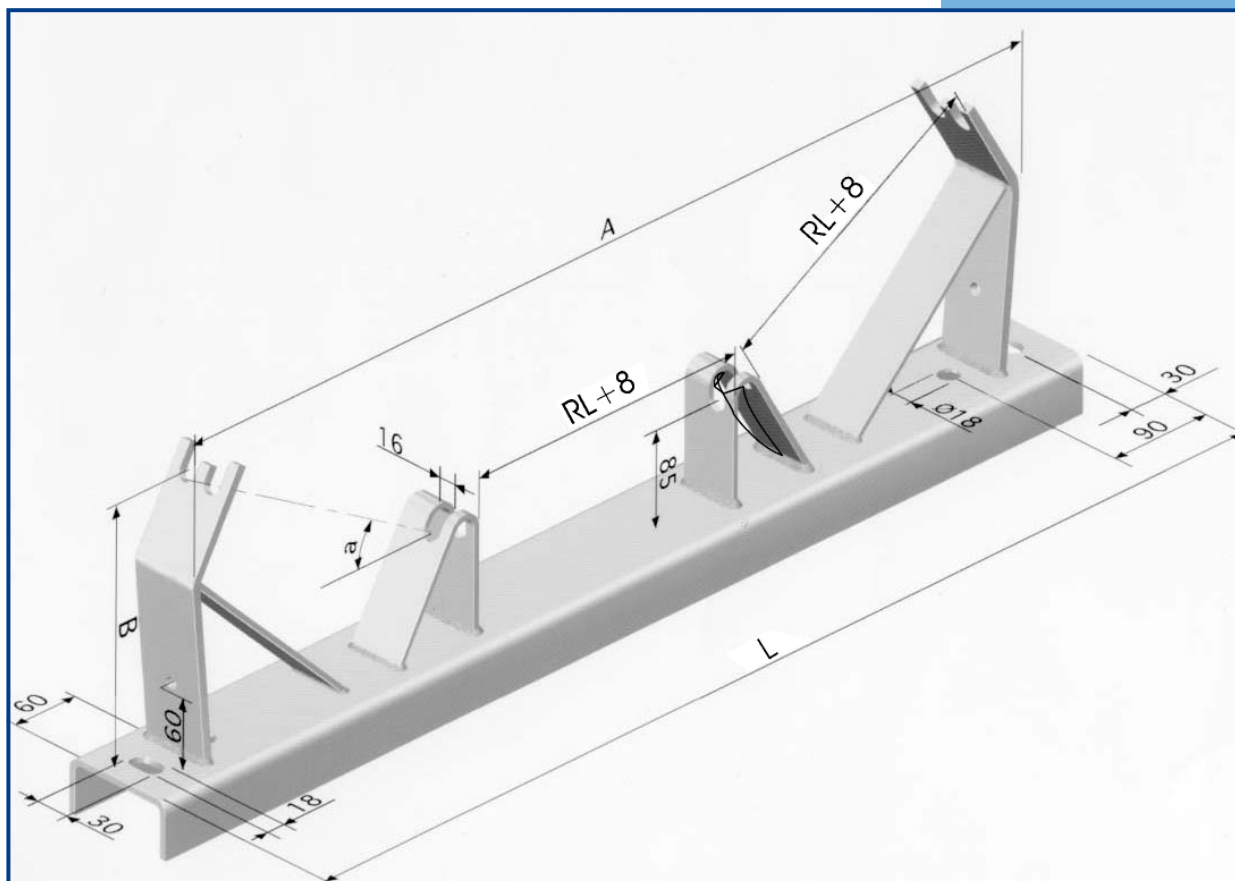

3-delige trogstellen op platijzer 80 x 8 mm



s.g.t nv
sq

Norm : NFE 53300
 Voor rollen : GUP \varnothing 63,5—89—108—133 mm, as 20 mm, SW14x10 mm
 Bescherming : Antiroest laag (op aanvraag warm verzinkt)
 Toespoor : Met 2° (zonder op aanvraag)

Band- breedte [mm]	\varnothing D [mm]	L [mm]	C [mm]	L' [mm]	C' [mm]	G [mm]	K [mm]	E [mm]	Gewicht				
									α 20	25	30	35	45
400	63,5 89 108	150	158	475	508	570	466	100	5,8	6	6,1	6,4	
500		190	198	575	608	680	566	100	6,6	6,8	7	7,3	7,8
650		240	248	725	758	830	716	100	7,7	7,9	8,2	8,5	9,1
800		290	298	875	908	980	866	100	8,7	9	9,3	9,7	10,4
800	133	285	298	875	908	980	866	125	9,9	10,3	10,6	11	10,4
1000		355	368	1115	1148	1210	1106	125	11,6	12	12,4	12,8	11,9
1200		425	438	1315	1348	1400	1306	125	13,2	13,7	14,2	14,8	13,5

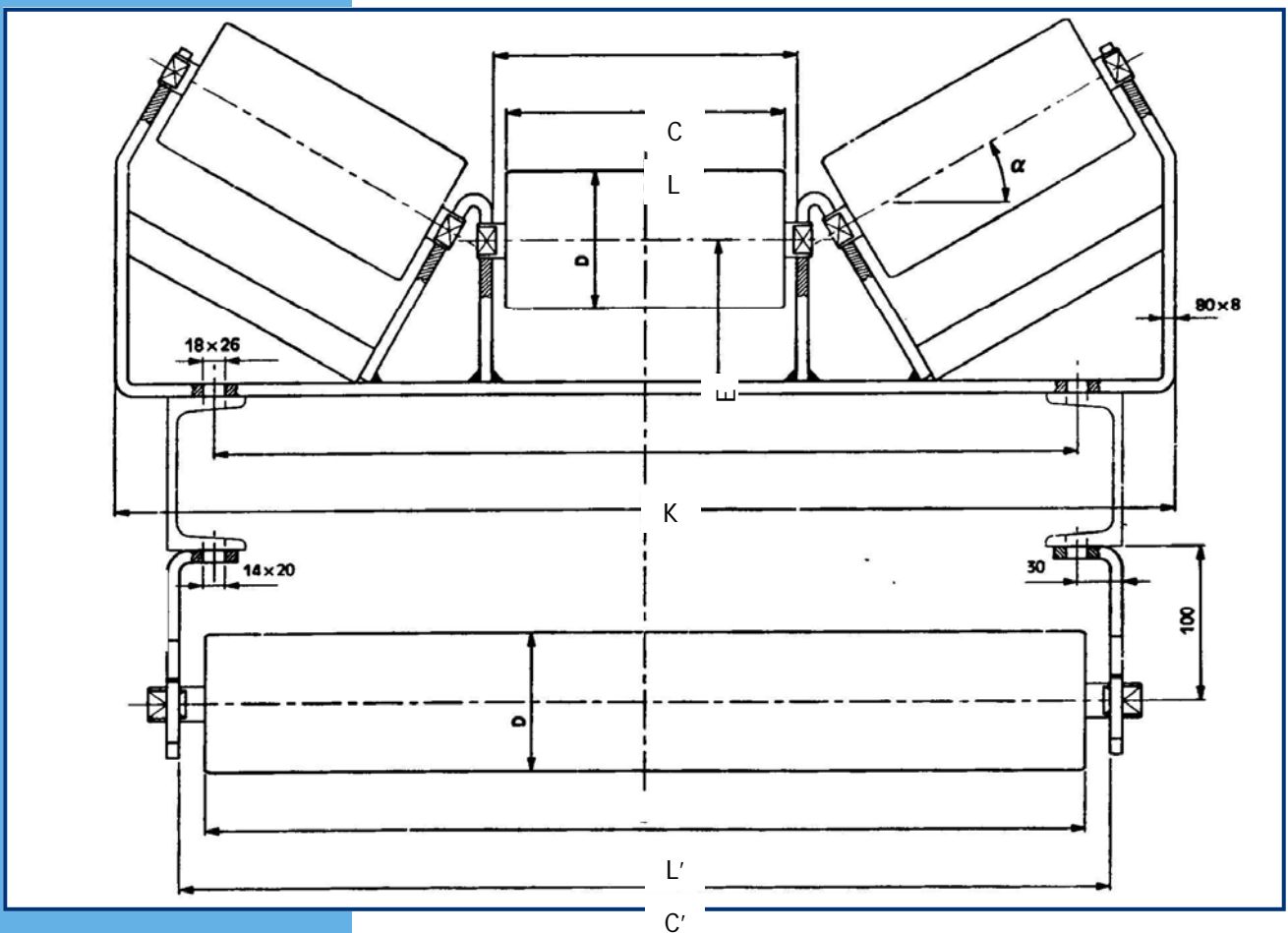



2-delige trogstellen op platijzer 80 x 8 mm

Norm : NFE 53300
 Voor rollen : GUP \varnothing 63,5—89 mm, as 20 mm, SW14x10 mm
 Bescherming : Antiroest laag (op aanvraag warm verzinkt)
 Toespoor : Met 2° (zonder op aanvraag)

Band- breedte [mm]	\varnothing D [mm]	L [mm]	C [mm]	L' [mm]	C' [mm]	G [mm]	K [mm]	E [mm]	Gewicht				
									α 20	25	30		
300	63,5	190	198	375	410	460	366	73	4,7	5,0	5,2		
	ou 89												
400	63,5	240	248	475	510	560	466	73	5,5	5,8	6,1		
	ou 89												
500	63,5	290	298	575	610	660	566	73	6,3	6,6	6,9		
	ou 89												
600	63,5	340	348	675	710	760	666	73	7,1	7,5	7,9		
	ou 89												
650	63,5	360	368	725	760	810	716	73	7,5	7,9	8,3		
	ou 89												

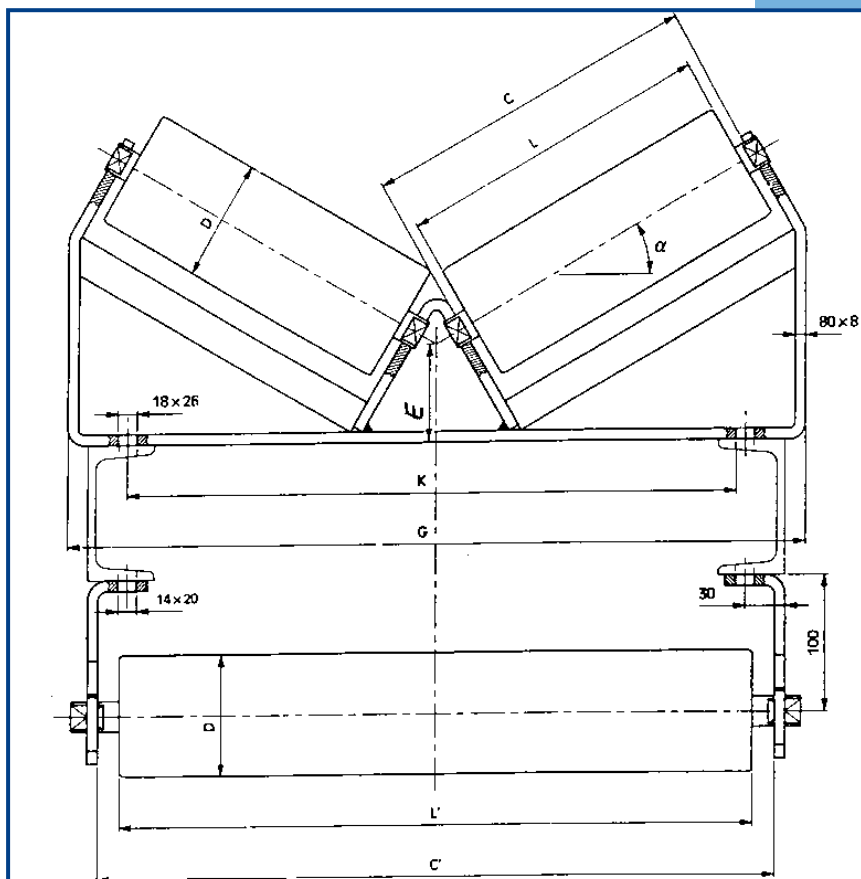

Standaard 2-delige trogstellen op U-60 koud gewalst



Norm : DIN
 Voor rollen : GUP Ø 63,5—89—108—133—159 mm, as 20 mm, SW15x10 mm
 Bescherming : Epoxy-coating, ovengebakken (op aanvraag warm verzinkt)
 Toespoor : Zonder (met 2° op aanvraag)

Band- breedte GB [mm]	Rol		Afstand plat EL [mm]	Lengte profiel L [mm]	Afstand gaten LS [mm]	Hoogte rollen			Gewicht (zonder rollen)					
	diam. D [mm]	lengte RL [mm]				h1 [mm]	h [mm]	H [mm]	α [°]					
	5	10							15	20	25	30		
400	63,5	250	256	700	640	75	120	151,75	4,65	4,79	4,94	5,09	5,26	5,45
	89					75	120	164,5						
	108					85	130	184						
500	63,5	315	321	800	740	75	120	151,75	5,08	5,22	5,37	5,52	5,69	5,88
	89					75	120	164,5						
	108					85	130	184						
650	63,5	380	386	950	890	75	120	151,75	5,76	5,93	6,11	6,30	6,51	6,74
	89					75	120	164,5						
	108					85	130	184						
	133					100	145	211,5						
800	63,5	465	471	1150	1090	75	120	151,75	6,66	6,88	7,10	7,34	7,60	7,88
	89					75	120	164,5						
	108					85	130	184						
	133					100	145	211,5						
1000	89	600	606	1350	1290	75	120	164,5	7,56	7,82	8,09	8,38	8,69	9,03
	108					85	130	184						
	133					100	145	211,5						
	159					130	175	254,5						

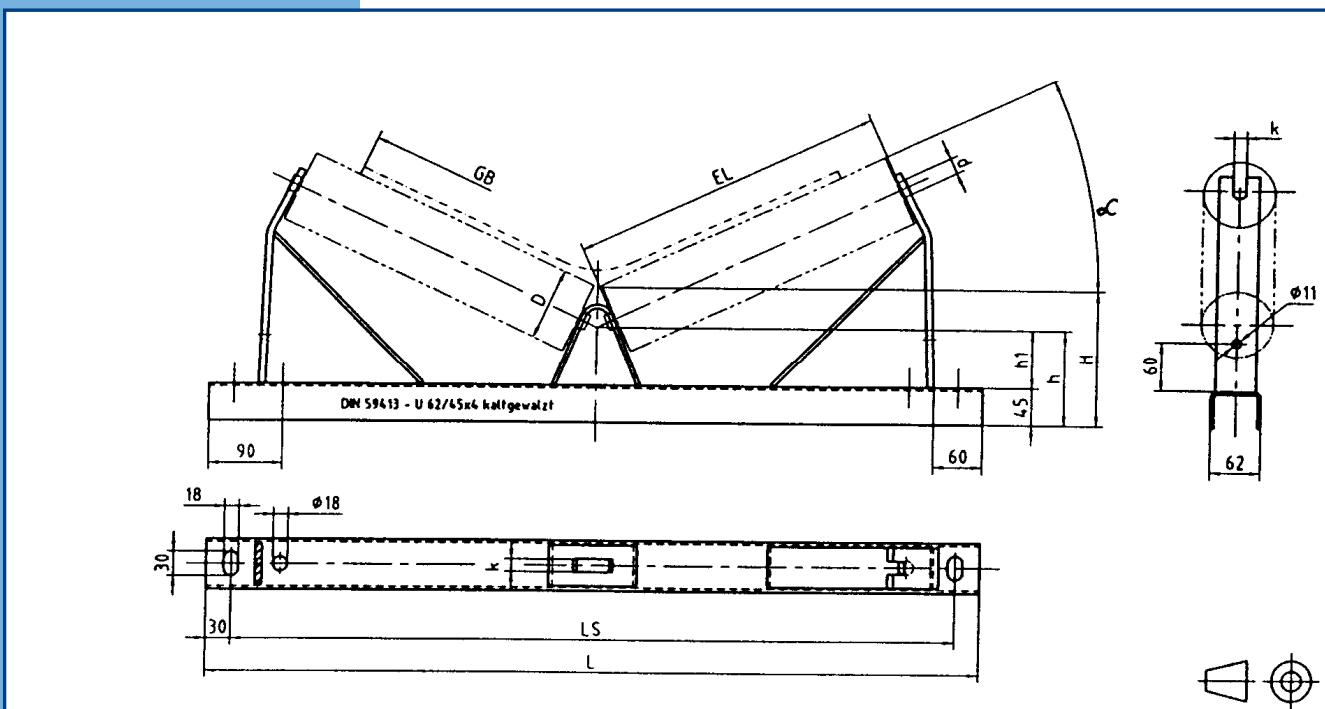



Standaard 2-delige trogstellen op U-100 koud gewalst

Norm : DIN
 Voor rollen : GUP Ø 63,5—89—108—133—159 mm, as 20 mm, SW15x10 mm
 Bescherming : Epoxy-coating, ovengebakken (op aanvraag warm verzinkt)
 Toespoor : Zonder (met 2° op aanvraag)

Band- breedte GB [mm]	Rol		Afst. plat EL [mm]	Lengte profiel L [mm]	Afstand gaten LS [mm]	Hoogte rollen			Gewicht (zonder rollen)					
	diam. D [mm]	lengte RL [mm]				h1 [mm]	h [mm]	H [mm]	α [°]					
	5	10							15	20	25	30		
400	63,5	250	256	700	640	75	125	156,75	6,56	6,69	6,84	7,00	7,16	7,35
	89					75	125	169,5						
	108					85	135	189						
500	63,5	315	321	800	740	75	125	156,75	7,27	7,40	7,55	7,71	7,87	8,06
	89					75	125	169,5						
	108					85	135	189						
650	63,5	380	386	950	890	75	125	156,75	8,35	8,52	8,71	8,90	9,11	9,33
	89					75	125	169,5						
	108					85	135	189						
	133					100	150	216,5						
800	63,5	465	471	1150	1090	75	125	156,75	9,80	10,02	10,24	10,48	10,74	11,02
	89					75	125	169,5						
	108					85	135	189						
	133					100	150	216,5						
1000	89	600	606	1350	1290	75	125	169,5	11,25	11,51	11,78	12,07	12,37	12,71
	108					85	135	189						
	133					100	150	216,5						
	159					130	180	259,5						

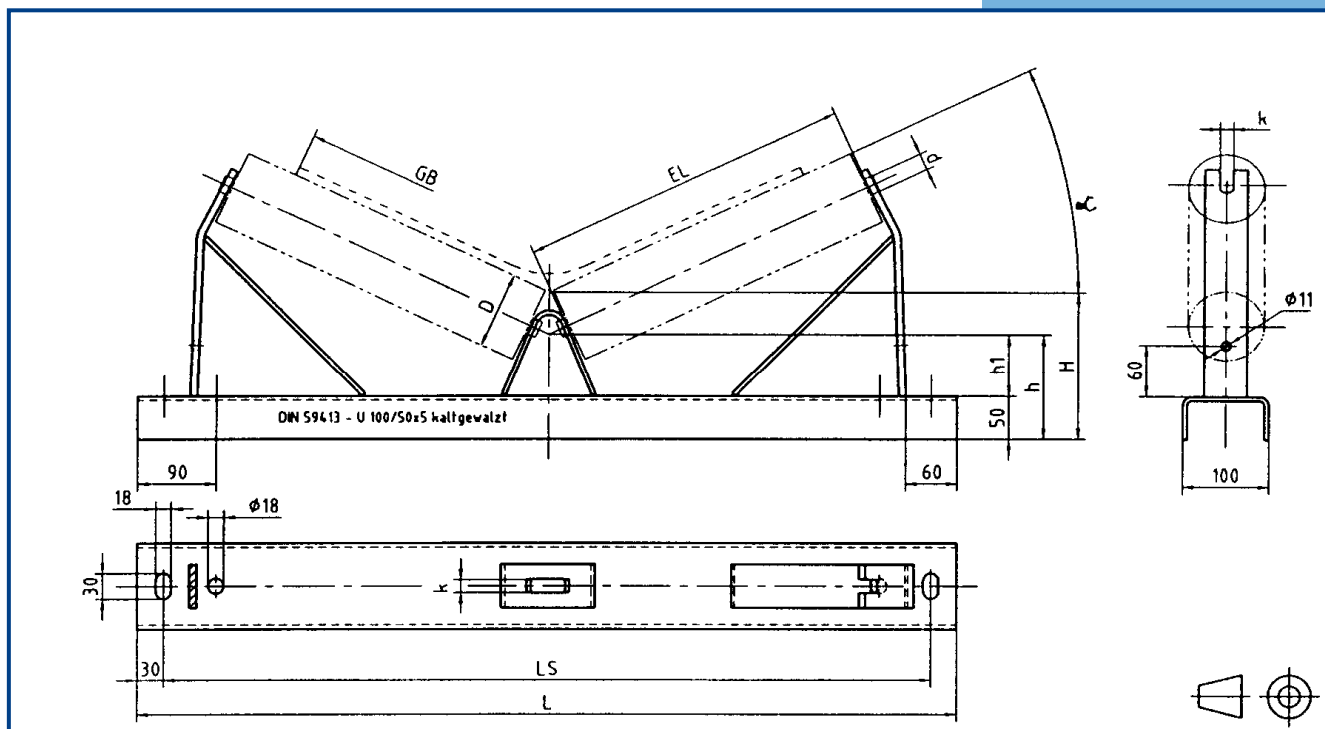

Standaard 3-delige trogstellen op U-60 koud gewalst



Norm : DIN
 Voor rollen : GUP Ø 63,5—89—108 mm, as 20 mm, SW15x10 mm
 Bescherming : Epoxy-coating, ovengebakken (op aanvraag warm verzinkt)
 Toespoor : Zonder (met 2° op aanvraag)

Band- breedte GB [mm]	Rol		Afstand plat EL [mm]	Lengte profiel L [mm]	Afstand gaten LS [mm]	Hoogte rollen			Gewicht (zonder rollen)								
	Ø D [mm]	lengte RL [mm]				h1 [mm]	h [mm]	H [mm]	α [°]								
	5	10							15	20	25	30	35	40	45		

400	63,5	165	171	700	640	75	120	151,75	4,65	4,79	4,94	5,09	5,26	5,45	5,66	5,90	6,19
	89					75	120	164,5									
	108					85	130	184									
500	63,5	200	206	800	740	75	120	151,75	5,08	5,22	5,37	5,52	5,69	5,88	6,09	6,33	6,62
	89					75	120	164,5									
	108					85	130	184									
650	63,5	250	256	950	890	75	120	151,75	5,76	5,93	6,11	6,30	6,51	6,74	7,00	7,29	7,64
	89					75	120	164,5									
	108					85	130	184									
800	63,5	315	321	1150	1090	75	120	151,75	6,66	6,88	7,10	7,34	7,60	7,88	8,20	8,56	8,99
	89					75	120	164,5									
	108					85	130	184									
1000	89	380	386	1350	1290	75	120	164,5	7,56	7,82	8,09	8,38	8,69	9,03	9,40	9,83	10,3
	108					85	130	184									

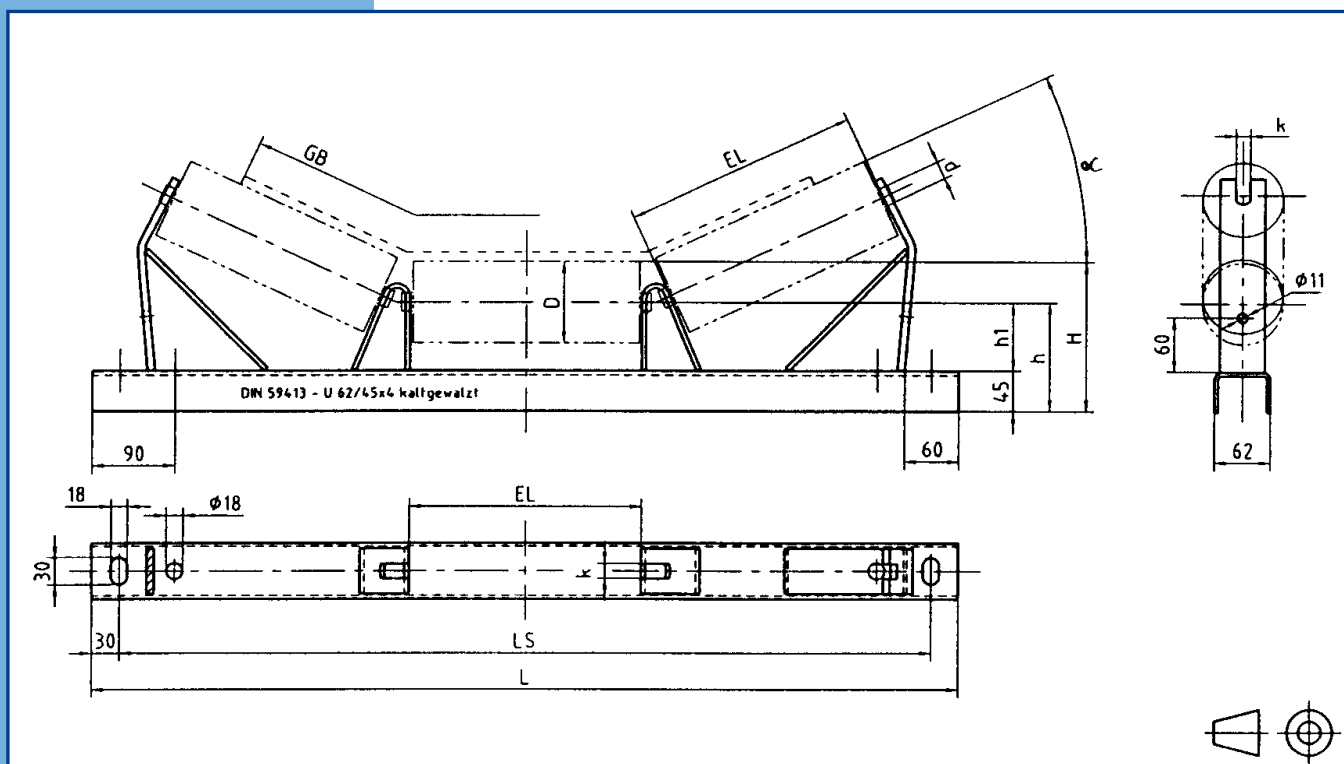



Norm : DIN
 Voor rollen : GUP Ø 63,5—89—108—133—159 mm, as 20 mm, SW15x10 mm
 Bescherming : Epoxy-coating, ovengebakken (op aanvraag warm verzinkt)
 Toespoor : Zonder (met 2° op aanvraag)

Bandbreedte GB [mm]	Rol		Afst. plat EL [mm]	Lengte profiel L [mm]	Afstand gaten LS [mm]	Hoogte rollen			Gewicht (zonder rollen)								
	Ø D [mm]	lengte RL [mm]				h1 [mm]	h [mm]	H [mm]	α 5	10	[°] 15	20	25	30	35	40	45
400	89	165	171	700	640	75	125	169,5	6,56	6,69	6,84	7,00	7,16	7,35	7,56	7,80	8,09
	108					85	135	189									
						85	135	189									
500	63,5	200	206	800	740	75	125	156,75	7,3	7,40	7,6	7,7	7,9	8,1	8,3	8,5	8,80
	89					75	125	169,5									
	108					85	135	189									
650	63,5	250	256	950	890	75	125	156,75	8,35	8,52	8,71	8,90	9,11	9,33	9,59	9,89	10,2
	89					75	125	169,5									
	108					85	135	189									
	133					100	150	216,5									
800	63,5	315	321	1150	1090	75	125	156,75	9,80	10,0	10,2	10,5	10,7	11,0	11,3	11,7	12,1
	89					75	125	169,5									
	108					85	135	189									
	133					100	150	216,5									
1000	89	380	386	1350	1290	75	125	169,5	11	12	12	12	12	12,7	13,1	13,5	14,0
	108					85	135	189									
	133					100	150	216,5									
	159					130	180	259,5									
1200	89	465	471	1600	1540	75	125	169,5	13	13	14	14,0	14	14,8	15,3	15,8	16,4
	108					85	135	189									
	133					100	150	216,5									
	159					130	180	259,5									

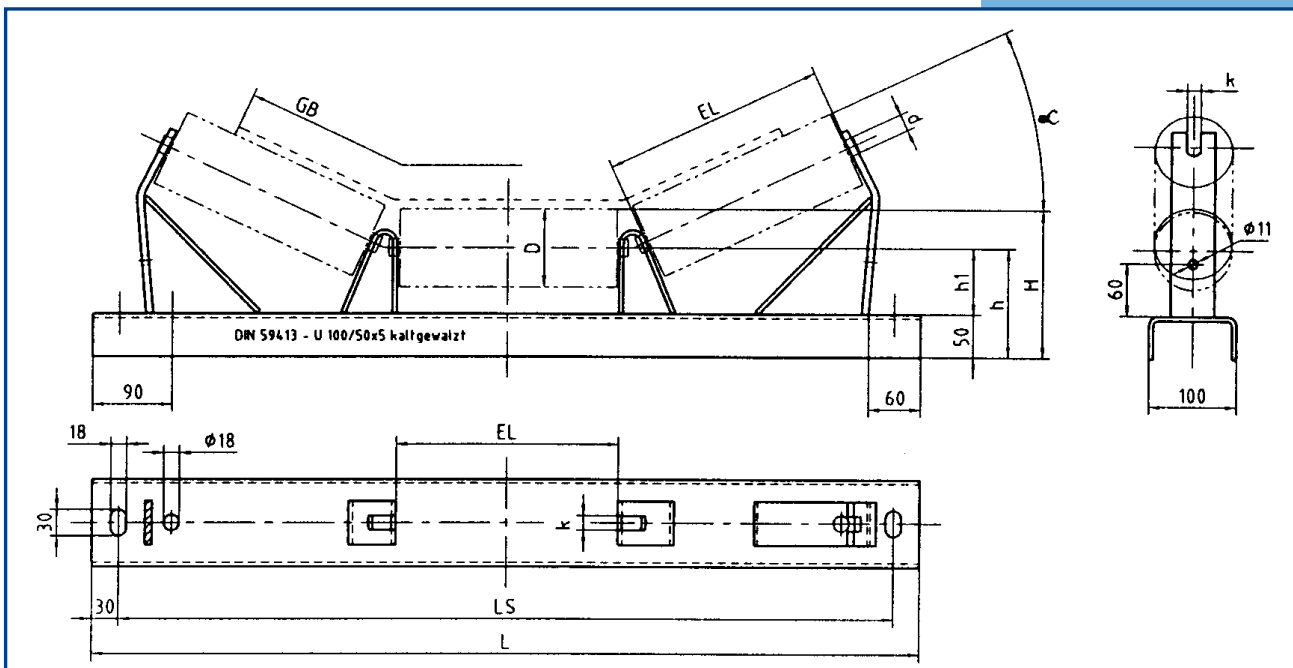

Steun voor bovenrol zware uitvoering



Norm :	DIN
As/SW :	17/12—20/14—20/15—25/18—30/22 mm
Voor rollen :	GUP Ø 63,5—89—108 mm—133—159 mm
Bescherming :	Epoxy-coating, ovengebakken (op aanvraag warm verzinkt)

Ashoogte rol h [mm]	Rol-diameter D [mm]	As-diameter d [mm]	Grootte van de sleuf k [mm]	Refer	Gewicht per stuk [kg]
70	63,5	17	13	2001573	1,80
	80	20	15	2001574	1,80
	89	20	16	2001575	1,80
	108	25	19	2001576	1,80
100	133	20	15	2001577	2,00
		20	16	2001578	2,00
	159	25	19	2001579	2,00
		30	23	2001580	2,00

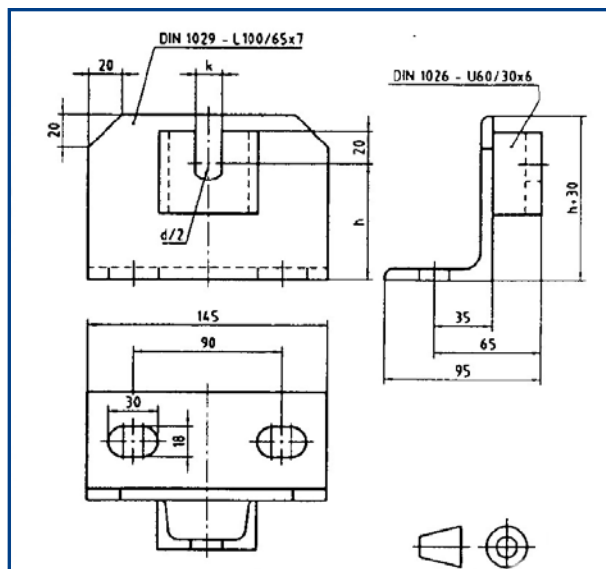

Keuze van de rollen en afstand van de langsliggers :

Rollengte RL/EL/AL [mm]	Band-breedte GB [mm]	Afstand profielen L [mm]	Afstand gaten LS [mm]
600/606/632	500	800	740
750/756/782	650	950	890
950/956/982	800	1150	1090
1150/1156/1182	1000	1350	1290
1400/1406/1432	1200	1600	1540

Gewenste ashoogte h [mm]	Rol-diameter D [mm]
70	63,5 89 108
100	133 159

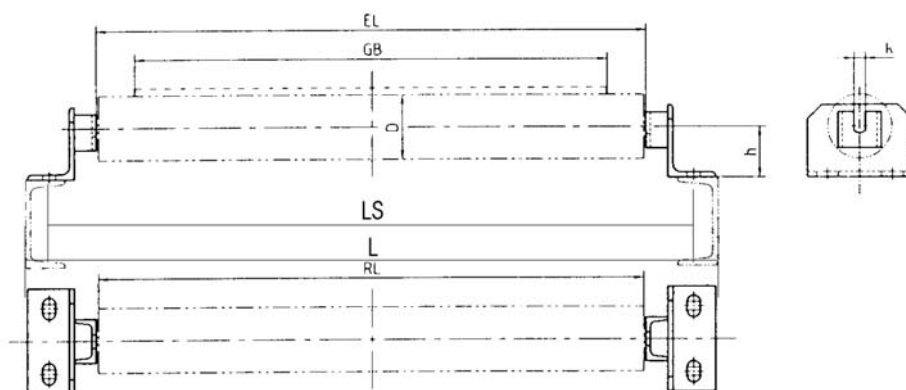

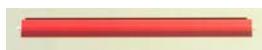

Steun voor onderrol zware uitvoering

Norm : DIN
 As/SW : 17/12—20/14—20/15—25/18—30/22 mm
 Voor rollen : GUP Ø 63,5—89—108 mm—133—159 mm
 Bescherming : Epoxy-coating, ovengebakken (op aanvraag warm verzinkt)

Ashoogte rol h [mm]	Rol-diameter D [mm]	As-diameter d [mm]	Grootte van de sleuf k [mm]	Refer.	Gewicht per stuk [kg]
70	63,5	17	13	2001562	1,80
	80	20	15	2001564	1,80
	89	20	16	2001565	1,80
	108	25	19	2001566	1,80
100	133	20	15	2001568	2,00
		20	16	2001569	2,00
	159	25	19	2001570	2,00
		30	23	2001572	2,00

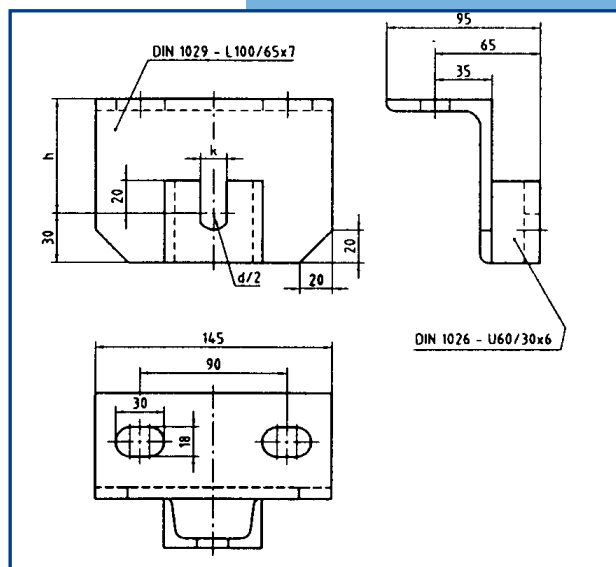

Keuze van de onderrollen en afstand van de langsliggers :

Rollenlengte RL/EL/AL [mm]	Band-breedte GB [mm]	Afstand profielen L [mm]	Afstand gaten LS [mm]
600/606/632	500	800	740
750/756/782	650	950	890
950/956/982	800	1150	1090
1150/1156/1182	1000	1350	1290
1400/1406/1432	1200	1600	1540

Gewenste ashoogte h [mm]	Rol-diameter D [mm]
70	63,5
	89
	108
100	133
	159

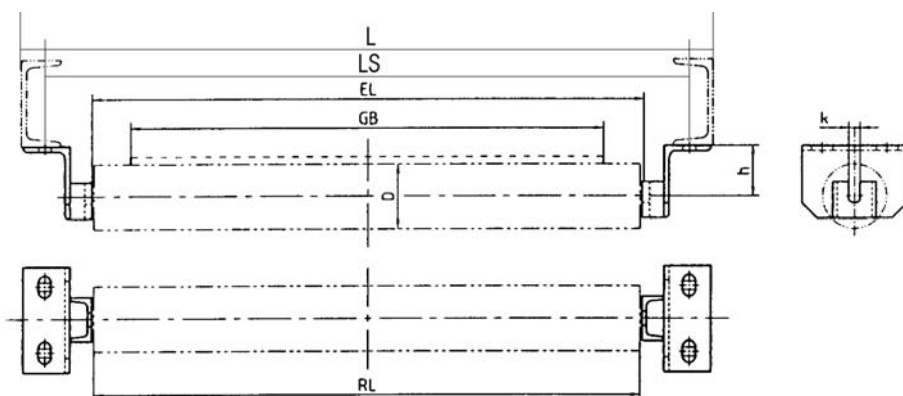

Steun voor onderrol standaard uitvoering



As/SW : 17/12—20/14—20/15—25/18—30/22 mm
 Voor rollen : GUP Ø 63,5—89—108 mm—133—159 mm
 Bescherming : Epoxy-coating, ovengebakken (op aanvraag warm verzinkt)

Ashoogte rol h [mm]	Rol-diameter D [mm]	As-diameter d [mm]	Grootte van de sleuf k [mm]	Refer.	Gewicht per stuk [kg]
70	63,5	17	13	2001561	1,00
	80	20	15	2001563	1,00
	89	20	16	2000032	1,00
	108	25	19	2000033	1,00
100	133	20	15	2001567	1,25
		20	16	2000036	1,25
	159	25	19	2000035	1,25
		30	23	2001571	1,25

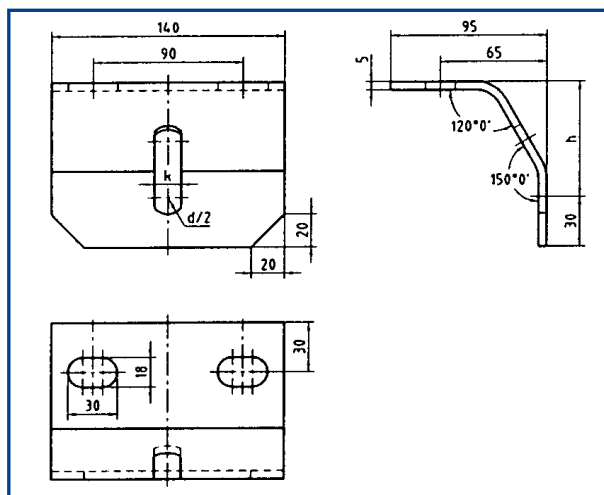

Keuze van de onderrollen en afstand van de langsliggers :

Rollengte RL/EL/AL [mm]	Band-breedte GB [mm]	Afstand profielen L [mm]	Afstand gaten LS [mm]
600/606/632	500	800	740
750/756/782	650	950	890
950/956/982	800	1150	1090
1150/1156/1182	1000	1350	1290
1400/1406/1432	1200	1600	1540

Gewenste ashoogte h [mm]	Rol-diameter D [mm]
70	63,5 89 108
100	133 159

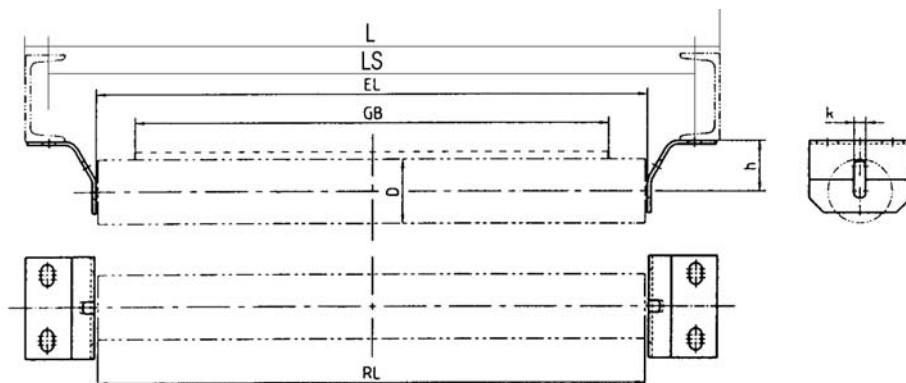





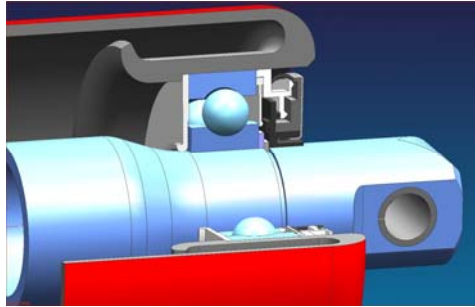

CONTACTEER ONS :

Algemeen (prijsaanvragen, bestellingen, facturatie, opvolging bestellingen, dienst na verkoop, ...):

Mevrouw **Pamela Bodart**
Management assistant
Chaussée de Wavre 362
B-1390 GREZ-DOICEAU
Tel: +32-10-84.29.25
Fax: +32-10-84.21.74
Mail : info@sgt-promati.com
www.sgt-promati.com

Verkoop Vlaanderen Key Account :

Dhr **Pascal Cornelis**
Directeur commercial sales & Marketing
+32-477/60.89.37
cornelis@sgt-promati.com

Verkoop Limburg en Antwerpen:

Dhr **Rob Poelmans**
Sales Representative
+32-473/66.79.19
Rob.Poelmans@sgt-promati.com

Verkoop Vlaanderen :

Dhr **Jeroen De Decker**
Sales Representative
+32-471/55.77.23
Jeroen.Dedecker@sgt-promati.com

Verkoop Nederland :

Dhr **Rene Snel**
Key Account Manager
+31-6-21.21.80.88
snel@sgt-promati.com

Dhr **Arjan Hofman**
Sales Representative
+31-615 821 026
Arjan.Hofman@sgt-promati.com

