

Weighing & Inspection



Thermo Scientific Oretronic IV Tramp Metal Detector

The Oretronic IV prevents your profits from turning into scrap

The Thermo Scientific Ramsey Oretronic IV tramp metal detector minimizes lost production time and helps you save money by providing an economical and reliable means to protect expensive crushers, conveyors and other process equipment from damage by tramp metal.

Tramp metal can stop your operation and the damage it causes to equipment can be expensive. That is why proactive operators and owners consider tramp metal detectors to be an essential part of their operation.



Weighing & Inspection Benelux

Hoofdkantoor: Brielstraat 112 - B 9990 Maldegem - T. +32 (0)50 71 09 20 - F. +32 (0)50 38 25 75 - info@wibe.be

Kantoor Nederland: Gooikensdam 16 - NL-4905 BN Oosterhout

Thermo Scientific Oretronic IV Tramp Metal Detector

The Thermo Scientific Oretronic IV tramp metal detector is designed for belt conveyors moving coal, iron pellets, minerals, cement, aggregates and other bulk materials. It can detect all types of metallic scrap, including bucket teeth, manganese steel mantles, bore crowns, bar scrap, chains, wear plates and tools. It can even detect tramp metal when buried in wet conductive materials. And, because it is insensitive to materials with high magnetic permeability and electrical conductivity, this tramp metal detector can be used in applications where conventional metal detectors produce an unacceptable false alarm rate.

It has a microprocessor-based control unit that automates system set-up and calibration. The operator interface provides easy-to-read indicators and a soft touch keypad designed to simplify setup and system maintenance, accompanied by a front cover reset button.

This tramp metal detector also features variable frequency to eliminate interference from other electrical equipment, password protection for security, and an optional RS-485 serial communication card.

Installation

The systems coils are made of impact-resistant polyvinyl chloride and designed to withstand stresses of up to ten times the force of gravity. The transmitter coil and dual-wound receiver coils mount on a support made of non-conductive materials. The transmitter coil is swing-mounted to protect the coil and support from being struck from oversized materials. A dual receiver coil is utilized to counteract interference from external sources, such as electric motors, lightning and radio transmitters.

System Components

- Microprocessor based control unit
- Receiver Coil
- Transmitter Coil
- Support Frame



Thermo Scientific Oretronic IV 4 Control

- Improved sensitivity
- NEMA-4X fiberglass enclosure
- External reset button
- Optional RS-485 comm card

Thermo Scientific Oretronic IV Coil System

- Impact resistant PVC and fiberglass design
- Non-conductive to eliminate interference with detection
- Top coil swing-arm to prevent damage from material impact
- Single coil option



Thermo Scientific Oretronic IV 6 Control

- Highest available sensitivity on the market
- Painted NEMA-4 steel enclosure
- External reset button
- Optional RS-485 comm card
- Optional heater for low temp applications, 115V or 230V

Features and Benefits

Simple Installation: The detector can be installed without cutting the belt and without utilizing special tools or instruments.

Microprocessor based: Advanced electronics with LCD graphic display with status indicator lights for easy reading, continuous backlit for ease of viewing indoor and outdoor.

Variable Frequency: You may set the operating frequency. Interference and false trips from motors, radios and other external devices are eliminated.

Quick Balance: This allows you to electronically balance the coils with the push of a key.

Coil Frame: Coils are made of impact-resistant PVC and mounted on a fiberglass support structure. The coils and entire support structure are impervious to moisture.

Coast Count: When system alarm or trip occurs the control will continue counting pieces of tramp detected until system stops

Offset Swing Arm: This protects the coils and reduces the likelihood that they will break due to over-height burden.

Single Coil (optional): The combination of the transmitter and receiver coils into a single, under-the-belt coil assembly eliminates damage from high burden depths and interference from overhead metal objects.

Distance Indication (optional): When incorporating a speed sensor, the tramp metal detector's display will show the distance from the coil to the tramp metal in tenths of feet.

Serial Communications (optional): Plug in RS-485 communications board.

Heater for Control (optional): 115 or 230V heater for cold temperature applications, only applicable with steel enclosure

Thermo Scientific Ramsey Oretronic IV Tramp Metal Detector with Available Options

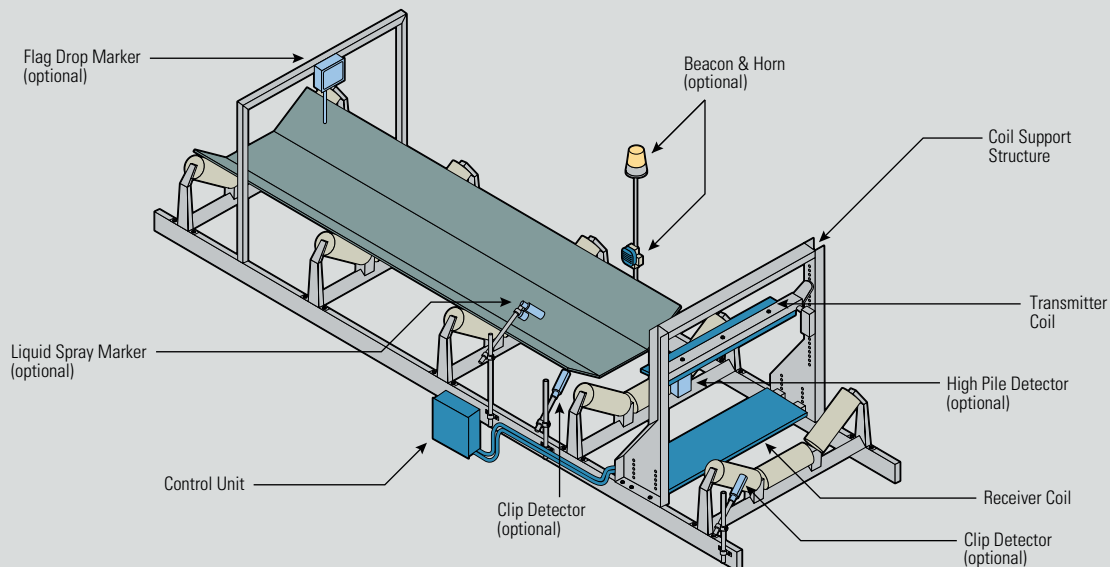

Available Options

- Single coil option
- Clip detector
- High pile detector
- Spray marker
- Flag drop marker
- Beacon Light
- Alarm Horn
- RS-485 Communication Card
- 115V or 230V Heater for steel enclosure

Oretronic IV Specifications

Control Unit Enclosure

Oretronic IV-4 Control: Reinforced fiberglass conforms to NEMA-4X, IP66 dust and water tight
432 mm (17 in) x 360 mm (14.2 in) x 184 mm (7.2 in)

Oretronic IV-6 Control: Painted mild steel conforms to NEMA-4, IP66 dust and water tight
687 mm (27 in) x 524 mm (20.6 in) x 230 mm (9.1 in)

Display

77 mm x 58 mm viewable LCD graphic display for easy reading,
continuous backlit for ease of viewing indoors and outdoors

Input Power Requirements

98-253 (fiberglass enclosure) or 115-230 VAC (steel enclosure) VAC, +10%, -15%
50/60 Hz
Single phase, 0.9A (fiberglass enclosure) or 2.8A (steel enclosure)

Environmental

Storage Temperature: -30°C to +70°C (-22°F to +158°F)
Operating Temperature: -40°C to +58°C (-40°F to +136°F)
Operating Temperature with Optional Heater: -50°C to +58°C (-58°F to +136°F)
Humidity: 10% up to 95%, non-condensing

Rating

User supplied 5A max, 250 VAC or 30 VDC
NO and NC Contacts: Alarm Indicator, Alarm, Marker Output
NC Contacts: Bypass, Power OK

Communication

Optional RS-485 serial communication

Coils and Support Assembly

FRP reinforced support assembly; coils sealed in PVC construction

Belt Speed

1.5 m/min to 550 m/min (5 ft/min to 1800 ft/min)

Software Languages

English, Spanish, German, Italian, French and Chinese Simplified

Manufacturing Quality

ISO-9001 Certified